



MODEL NO.

B2330

**Goalrilla E1
BASKETBALL SYSTEM**

OWNER'S MANUAL

1. **Read this manual carefully before starting assembly.** Read each step completely before beginning each step.
2. **Some smaller parts may be shipped inside larger parts. Check inside all parts and cartons before assembling or ordering parts.**
3. **To make assembly of your basketball system easier, use the Hardware Identifier on page 3 and 4 to identify and sort all fasteners. Check all cartons for kits. All hardware is not located in one kit.**
4. **Do not tighten hardware until instructed to do so.** If hardware is tightened too soon, mounting holes may not align and parts may not easily fit together. Leave locknuts slightly loose until you are instructed to tighten them.
5. **Save this instruction in the event that the manufacturer has to be contacted for replacement parts.**

Please Do Not Return This Product To The Store!

Contact Escalade® Sports customer service department at:

Phone: 1-888-USA-GOAL Toll Free!

Fax: 1-866-873-3536 Toll Free!

E-mail: basketball@escaladesports.com

Mailing Address:

Escalade Sports
PO Box 889
Evansville, IN 47706



Please visit our World Wide Web site at: www.goalrilla.com

ON-LINE TROUBLE SHOOTING

TECHNICAL ASSISTANCE

ON-LINE PARTS REQUESTS

FREQUENTLY ASKED QUESTIONS

ADDITIONAL ESCALADE® SPORTS PRODUCT INFORMATION

ESCALADE®

S P O R T S

2L-7167-00

Escalade® Sports products may be manufactured and/or licensed under the following patents.

6419596, 6179733, 5919102, 5071120, 4798381, 4424968, D326128

Additional patents may be pending. One or more of the listed patents and/or pending patents may cover specific product.

©2008 Escalade® Sports

SAFETY INSTRUCTIONS

FAILURE TO FOLLOW THESE WARNINGS MAY RESULT IN SERIOUS INJURY AND/OR PROPERTY DAMAGE.
Owner must ensure that all players know and follow these rules for safe operation of the system.

WARNING

FAILURE TO FOLLOW THESE WARNINGS MAY RESULT IN SERIOUS INJURY AND/OR PROPERTY DAMAGE.

Owner must ensure that all players know and follow these rules for safe operation of the system.

- Only hang from the rim briefly to regain balance or avoid injuring others. Release the rim as soon as safely possible.
- During play, especially when performing dunk type activities, keep player's face away from the backboard, rim, and net. Serious injury could occur if teeth/face come in contact with backboard, rim, or net.
- Do not slide, climb, or play on pole.
- When adjusting height, keep hands and fingers away from moving parts.
- Do not allow children to adjust system.
- During play, do not wear jewelry (rings, watches, necklaces, etc.) Objects may entangle in net.
- Keep water and organic material away from pole. Pole can rust and fail.
- Once a month check pole and all metal parts for rust. Completely remove rust and repaint with exterior enamel. If rust has penetrated any steel part, replace that part immediately.
- Check system before each use for loose hardware, signs of rust and instability. Repair before each use. Never play on damaged equipment.
- Wear a mouthguard when playing to avoid dental injuries.

4L-8090-00

SAFETY INSTRUCTIONS

FAILURE TO FOLLOW THESE SAFETY INSTRUCTIONS MAY RESULT IN SERIOUS INJURY, PROPERTY DAMAGE AND WILL VOID WARRANTY.

Owner must ensure that all players know and follow these rules for safe operation of the system. To ensure safety, do not attempt to assemble this system without following the instructions carefully. Proper and complete assembly, use and supervision is essential for proper operation and to reduce the risk of accident or injury. A high probability of serious injury exists if this system is not installed, maintained, and operated properly.

- If using a ladder during assembly, use extreme caution.
- 4 people are recommended for this operation.
- Seat the pole sections properly (if applicable). Failure to do so could allow the pole sections to separate during play.
- Before digging contact utility company to locate underground power cables, gas and water lines. Ensure there are no overhead power lines within 20 ft. (7m) radius of pole location.
- Climate, corrosion or misuse could result in system failure.
- If technical assistance is required, contact the manufacturer.
- Minimum operational height is 6'6" (1.98m) to the bottom of backboard.

*Most injuries are caused by misuse and/or not following instructions.
Use caution when using this system.*

WARNING!

Failure to observe this warning may cause property damage and/or serious injury. (Affixed to backboard)

Only hang from the rim briefly to regain balance or avoid injuring others. Release the rim as soon as safely possible.
Rim height adjustments should be made under parental supervision. Wear a mouth guard when playing to avoid dental injuries.
During play, do not wear jewelry (rings, watches, necklaces, etc). Objects may entangle in net.

HARDWARE IDENTIFIER

19

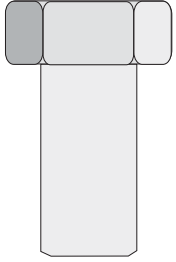

1/2-13 x 1"
Hex Bolt
(2 pieces)

3

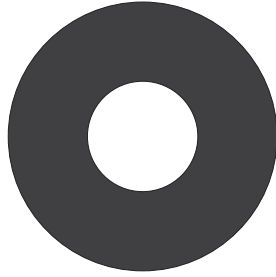

1/2" Flat Washer Black
(14 pieces)

5

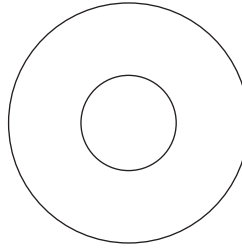

1-1/4" DIA. Plastic Washer
(22 pieces)

4

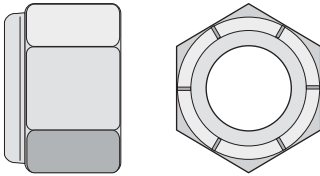

1/2"-13
Nylon Lock Nut
(6 pieces)

7

1/2-13 x 11"
Hex Bolt
(1 pieces)

37

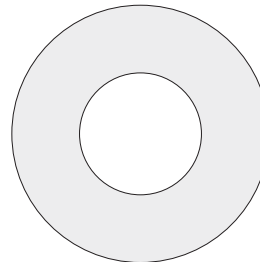

5/8" Flat Washer
(8 pieces)

14



18

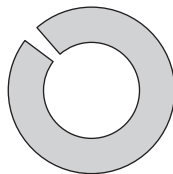

1/2" SPLIT
LOCK WASHER
(2 PIECES)

34

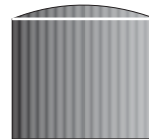

5/8" THREAD
PROTECTOR
(4 PIECES)

12

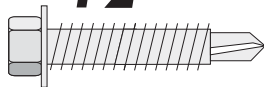

#10 x 1 1/8"
Self Tapping Screw
(8 Pieces)

3/4 OD x 6-3/4 Spacer
(1 piece)

HARDWARE IDENTIFIER

24

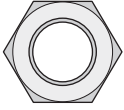

3/8"-16
HEX NUT
(4 PIECES)

29

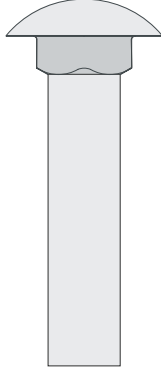

3/8-16 X 1 3/4"
Carriage Bolt
(4 Pieces)

26

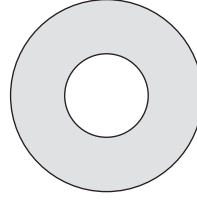

3/8" FLAT WASHER
(4 Pieces Rim Kit)

32

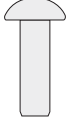

8 X 1/2"
Thread Forming Screw
(4 Pieces)

These parts are located inside rim kit

20

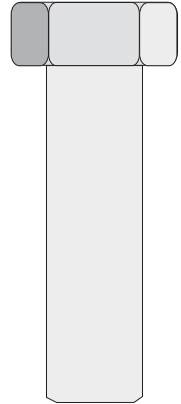

1/2-13 x 1 3/4"
Hex Bolt
(2 pieces)

35

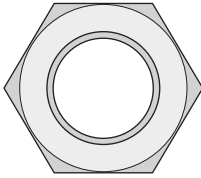

5/8"-11
Hex Nut
(12 pieces)

8

1/2-13 x 12"
Hex Bolt
(3 pieces)

36

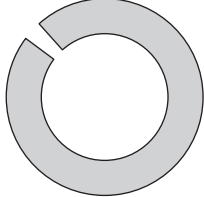

5/8" SPLIT
LOCK WASHER
(4 PIECES)

33

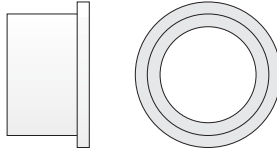

Board Bushing
(2 pieces)
Some may be
already installed

22

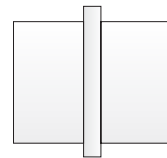

Two way Step Bushing
(2 Pieces)

INSTALLATION TIMELINE

1. Prior to anchor system and goal assembly, call utility services for location of underground utility lines before you dig.
2. Vertical main post assembly is a two part process.

PART 1

- Day 1.** Complete Anchor System Installation Instructions. (Below)
- Day 2-4.** Allow concrete to cure.

PART 2

- Day 5.** Complete Goalrilla™ assembly instructions. (Requires four adults)

ANCHOR SYSTEM INSTALLATION INSTRUCTIONS (Day 1)

⚡ WARNING

Before digging hole for anchor system, check for buried power, gas, water, and telecommunication lines! Failure to do so could result in serious or fatal injury! Contact your local utility company if unsure.

Items needed (not included)

- | | |
|---|------------------|
| 9 - 80 lb. bags of concrete | 1 - wheel barrow |
| 1 - post hole digger (optional) | 1 - garden hose |
| 1 - 15/16" wrench | 1 - level |
| 1 - concrete form (see note after step 2) | 1 - tape measure |

Note: For best results with less vibration, anchor system should be independent of court. If pouring concrete for both at same time, add an expansion joint in between.

1. Determine the location of the anchor system. The proper location is as close to the court without making contact, as shown in Figure 1. This, however, is a general rule. If you need to locate the anchor system in a location other than this, use the following dimensions as a guide.

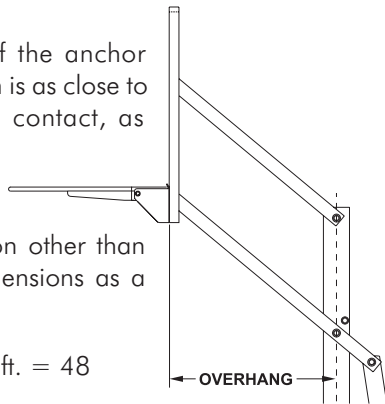

Overhang when adjusted to 10 ft. = 48"

2. Assemble anchor system as follows: Thread nut (#35) to bottom of threads on anchor bolt (#39) insert threads of anchor bolt (#39) through hole on anchor plate (#38) and secure with nut (#35). Repeat this step for the remaining anchor bolts. See Figure 2. Note: Each leg of anchor bolts should face the anchor bolt to the right. See Detail A.

Detail A Bottom View

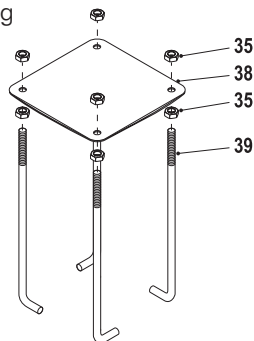
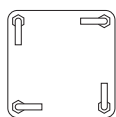
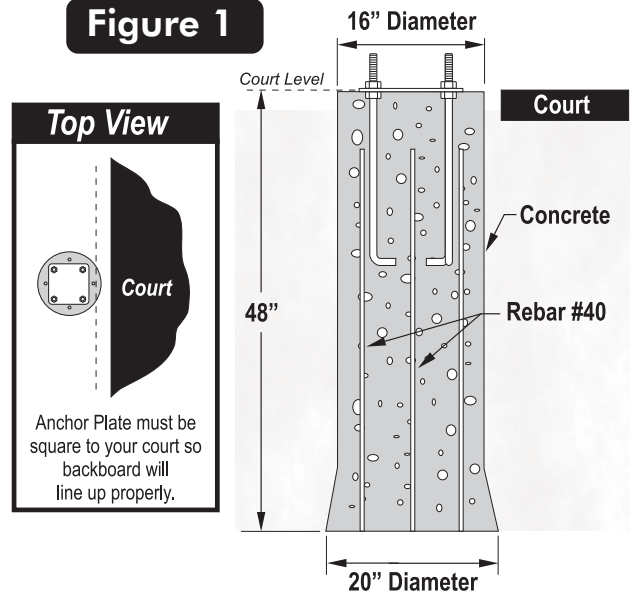

Figure 2

Figure 1



Note: Using a concrete form for the top 4" of the concrete is recommended. Cardboard forms can be purchased at some hardware and home stores or a wooden form can be constructed out of 2 x 4's.

3. Mix and pour concrete into hole. Follow instructions on concrete bag. Stop about 18" below court level.
4. Insert four reinforcement bars (#40) into concrete 8" apart creating a square in center on hole.
5. Place form in desired location and finish pouring concrete up to court level.
6. Push anchor system into concrete and agitate to work out voids in concrete. Immediately use a level to level and square anchor plate to playing surface. Clean off any concrete that may be on exposed threads.

Note: The bottom four nuts will be forever embedded in concrete.

Let concrete stand for a MINIMUM of 72 hours.

GOALRILLA™ ASSEMBLY INSTRUCTIONS (Day 5)

NOTE: It is important for the installer to understand the necessity of the Plastic washers (#5) provided. These washers adequately space painted parts at all pivot points. Neglecting the use of these washers will result in rusted parts.

NOTE: All board arms are made of rectangular tubing. Tightening hardware too tight may damage tubing and make adjustment of system difficult.

1. Slide Actuator Sleeve (#15) over Actuator (#16) and place Actuator Cap (#13) on top. Slide Pivot Tube (#14) in hole near the top of Actuator until equal amounts stick out on both sides of Actuator. See Figure 3.

NOTE: It may be necessary to use a hammer or rubber mallet to tap in Spacer.

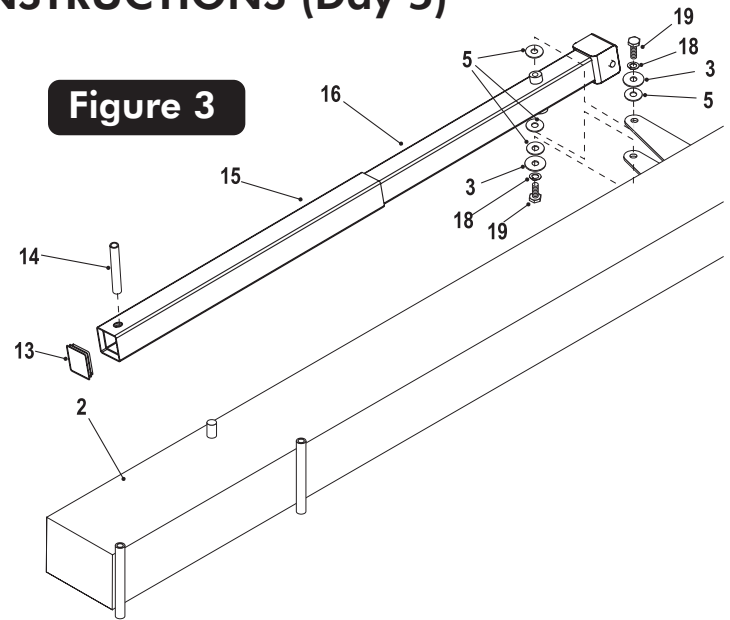

2. Lay Pole (#2) on its side on two padded saw horses. Attach Actuator (#16) to Pole (#2) using one bolt (#19), split lockwasher (#18), washer (#3) and two plastic washers (#5) to thread into each side of Actuator. See Figure 3. Do not tighten bolts yet.

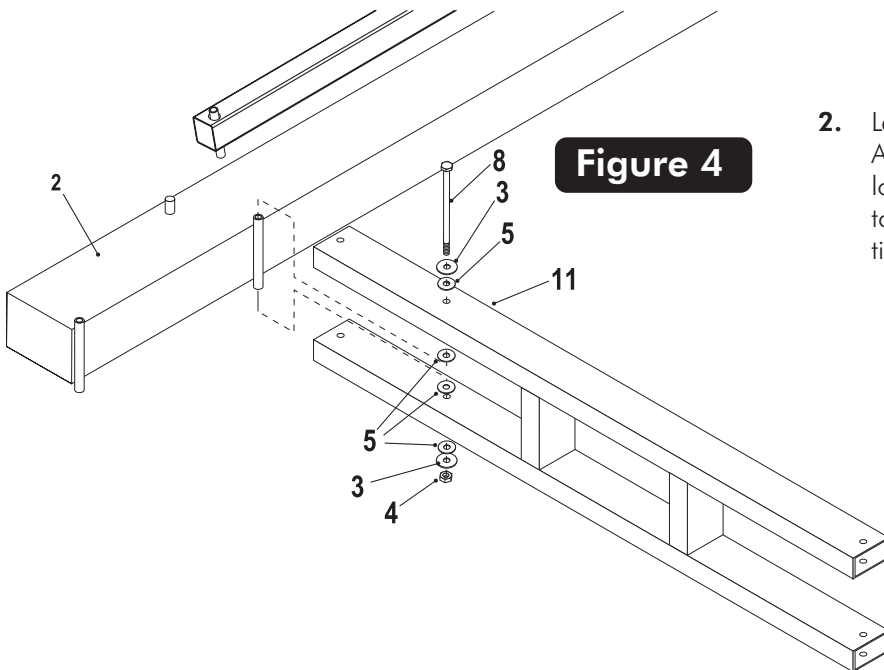

3. Attach lower arm (#11) to Pole (#2), as shown in Figure 4, using a bolt (#8), two flatwashers (#3), four plastic washers (#5) and hex nut (#4).

Note: make sure "Goalrilla lettering is right side up. Do NOT tighten bolt (#8) at this time.

4. Secure Actuator (#16) to Lower Arm (#11) using one bolt (#8), two flatwashers (#3), four plastic washers (#5) and one hex nut (#4). See Figure 5. Tighten both bolts (#8) securing Lower Arm (#11).

Note: Tighten bolts snug but, do not over tighten. Board Arms must pivot freely.

5. If the four Tube Plugs (#10) are not already installed insert them into open ends of Lower Arm (#11). It may be necessary to use a hammer or rubber mallet to tap plug in.

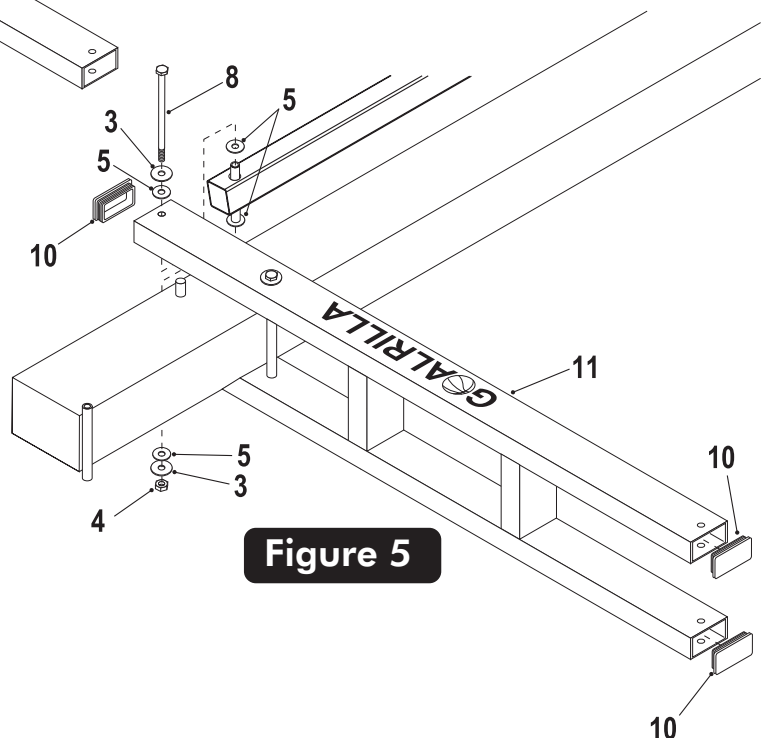

- Attach Upper Arms (#6) to Pole (#2), as shown in Figure 6, using a bolt (#7), two flatwashers (#3), four plastic washers (#5) and hex nut (#4).

Note: Tighten bolts snug but, do not over tighten. Board Arms must pivot freely.

- If the two Tube Plugs (#9) are not already installed insert them into open ends of Upper Arm (#6). It may be necessary to use a hammer or rubber mallet to tap plug in.

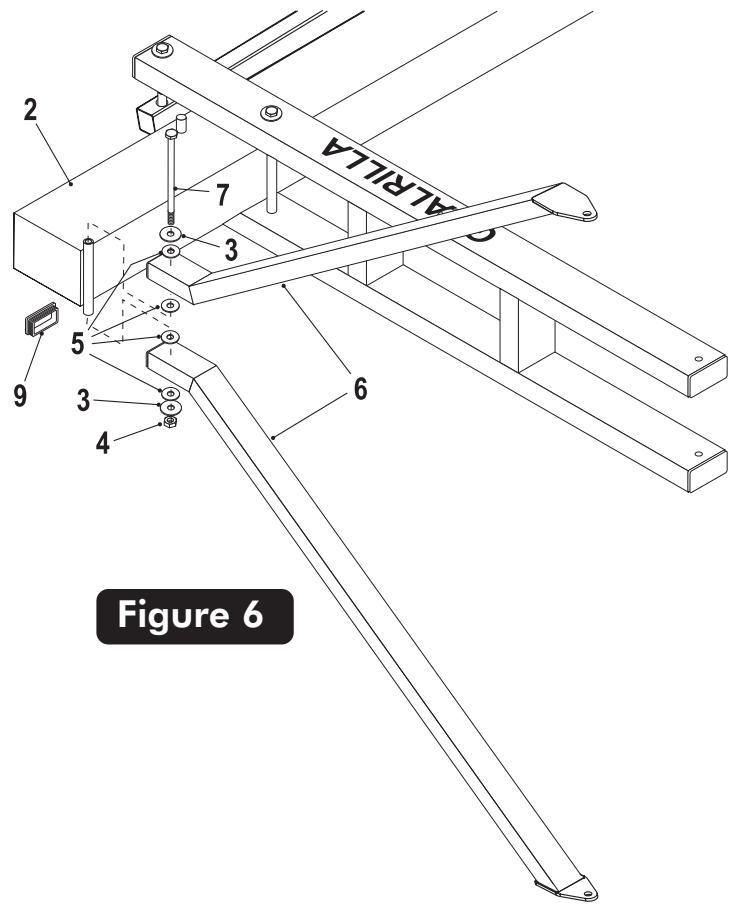

Figure 6

CAUTION!

PLACING THE POST ON THE ANCHOR SYSTEM REQUIRES AT LEAST FOUR CAPABLE ADULTS. POLE WILL WANT TO LEAN WHILE ATTEMPTING TO STAND IT UP ON ANCHOR BOLTS.

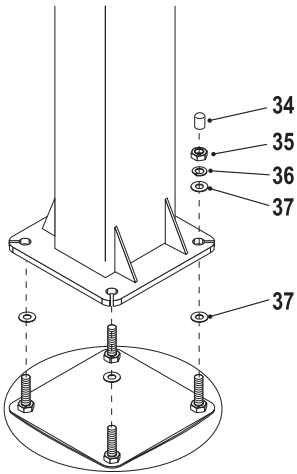

Figure 7

BE SURE CONCRETE HAS BEEN ALLOWED TO CURE FOR AT LEAST 3 DAYS

- Locate hardware needed to mount pole to anchor bolts. You will need, eight flatwashers (#37), four lock washers (#36), four hex nuts (#35) and four thread protectors (#34).

- Put a flat washer (#37) on each anchor bolt. Lift post onto anchor system and secure with one flatwasher (#37), one lock washer (#36) and one hex nut (#35) for each anchor bolt. Tighten all four hex nuts tight.

- Slide Actuator Handle (#42) onto shaft on the back of Actuator (#16). Line up hole in shaft with hole in Actuator Handle and insert Pull Pin (#41) to secure.

- To aid in the assembly of the backboard lower the lower board arm (#11), by turning the Actuator Crank, until the lower arm makes contact with the Safety Stop.

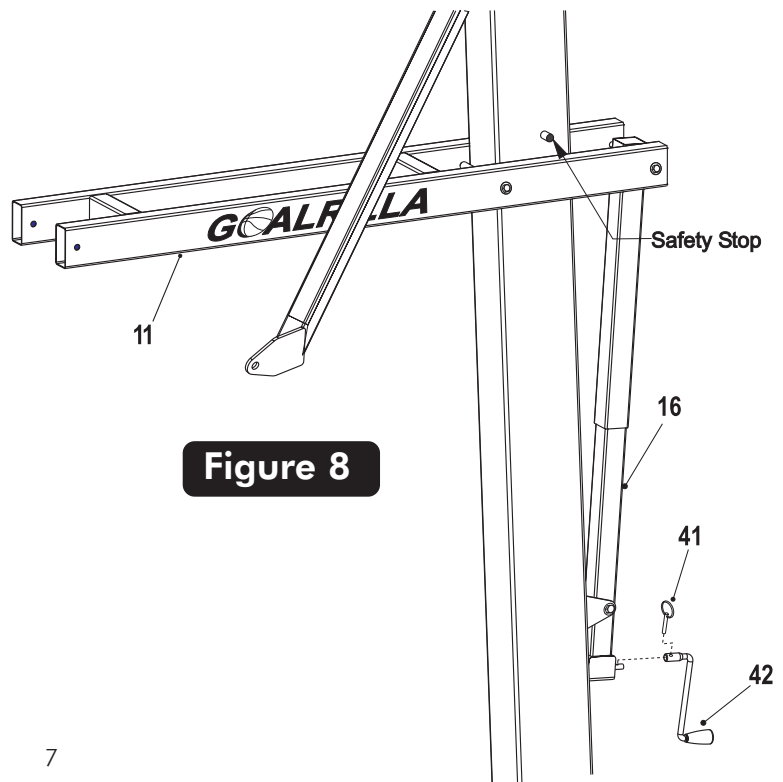
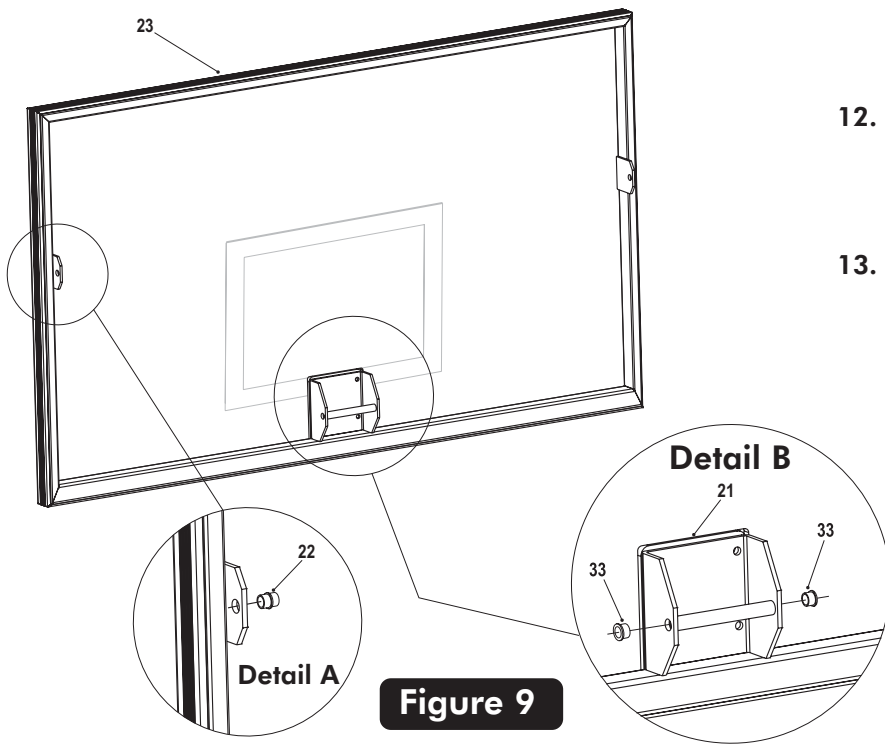

Figure 8



12. Insert a Two Way Step Bushing (#22) in to the inside of bracket on each side of the Backboard (#23) as shown in Detail A.

13. Insert two Board Bushings (#33) in to the rim support (#21). See Detail B.

Figure 9

! CAUTION!

ATTACHING BACKBOARD TO BOARD ARMS REQUIRES AT LEAST FIVE CAPABLE ADULTS.

! CAUTION!

HANDLE BACKBOARD WITH CARE, IT IS A GLASS PRODUCT. ALWAYS WEAR SAFETY GLASSES AND GLOVES WHEN HANDLING GLASS.

14. With at least four capable people, raise the backboard assembly up and have the fifth person attach Lower Board Arms to the Rim Support (# 21) on backboard using one bolt (#8), two washers (#3), two Plastic washers (#5) and two Locknuts (#4). See Figure 10.

Note: DO NOT over tighten these bolts. This is a pivot point. Snug is tight enough.

15. Attach Upper Board Arms to upper mounting tubes on backboard using two bolts (#20), two washers (#3) and two Locknuts (#4). See Figure 10.

Note: DO NOT over tighten these bolts. This is a pivot point. Snug is tight enough.

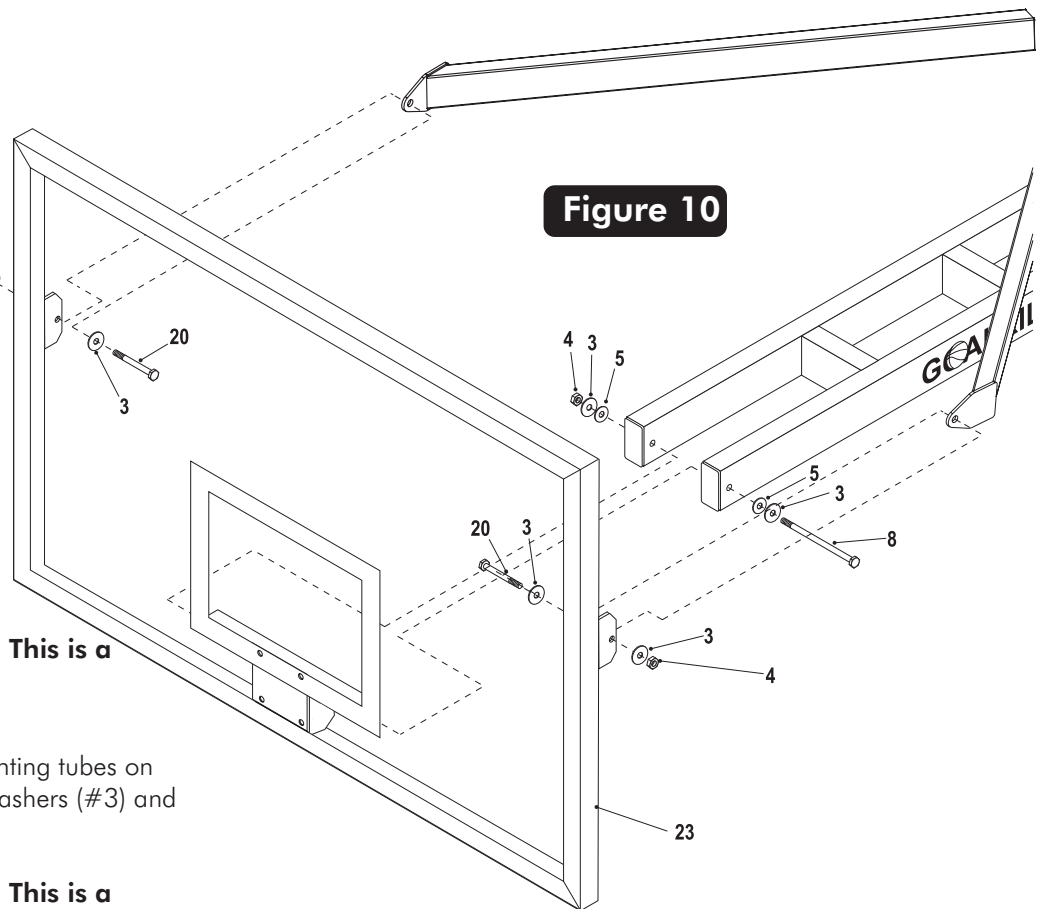

Figure 10

! CAUTION!

INSTALL RIM EXACTLY AS SHOWN. FAILURE TO DO SO COULD DAMAGE GLASS.

16. Mount Goal Assembly (#28) and Rim Pad (#27) to Backboard, as shown in Figure 11, using four bolts (#29), washer (#26) and four nuts (#24). Tighten Fasteners finger tight, leave loose enough to level rim.

17. Place a level across rim assembly and adjust rim until it is level. Finish tightening the four nuts.

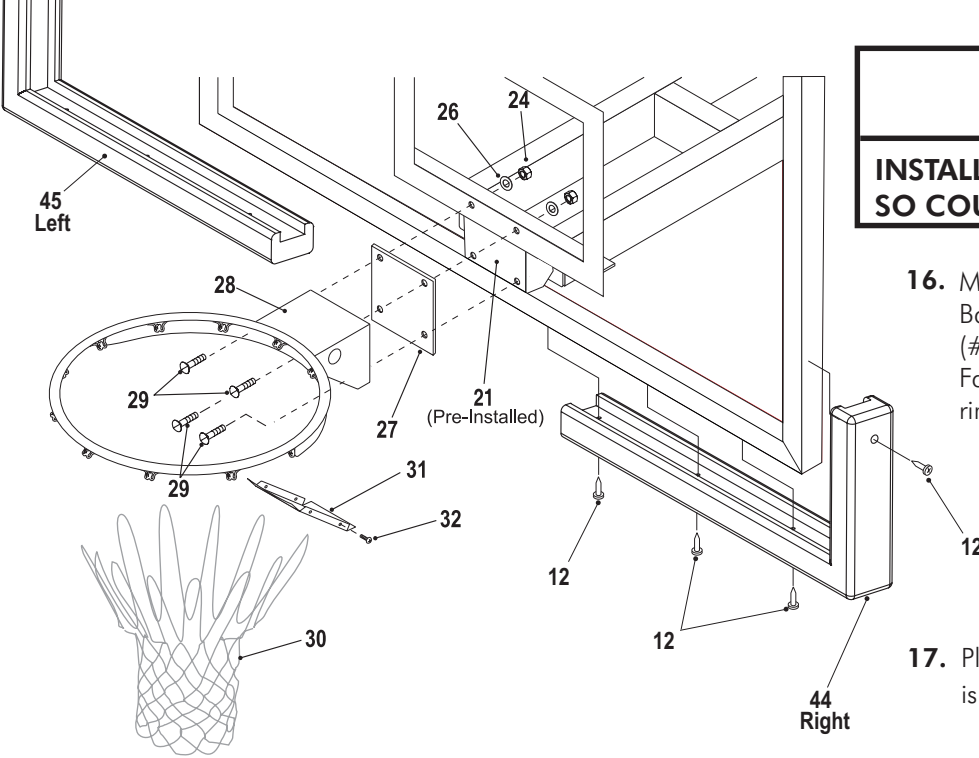
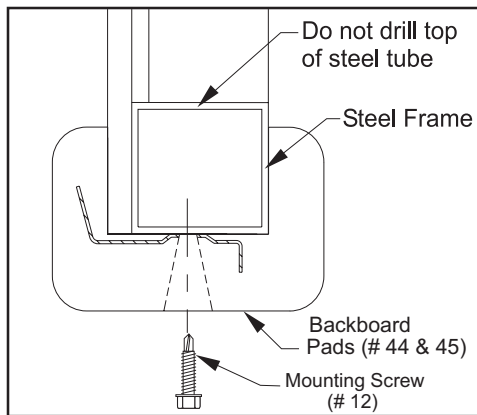

Figure 11



Detail C

! CAUTION!

NEVER USE RIM WITH COVERPLATE REMOVED!

- 18.** Attach Rim Cover Plate (#31) using four screws (#32). See Figure 11.
- 19.** Check all nuts and bolts so everything is tightened properly. Do NOT over tighten pivot points, snug is tight enough.
- 20.** Use the Backboard Pads (#44 & 45) as a template and mark the hole locations on the backboard frame. Pads will be marked either R or L. See Figure 11.
- 21.** Drill 1/8 pilot holes through aluminum trim and into steel backboard frame as shown in Detail C. **Do not drill through both sides of tube.**
- 22.** Secure Backboard Pads using screws provided (#12). **Note: Power screw driver recommended for screw installation. Do not over tighten screws.**
- 23.** Adjust unit to 7-1/2 feet. Use a tape measure to measure from the top of the rim to the playing surface. Stick Height Decal (#17) to back of actuator (#16) with the "7.5" mark aligned with bottom of Actuator Sleeve (#15). See Figure 12.

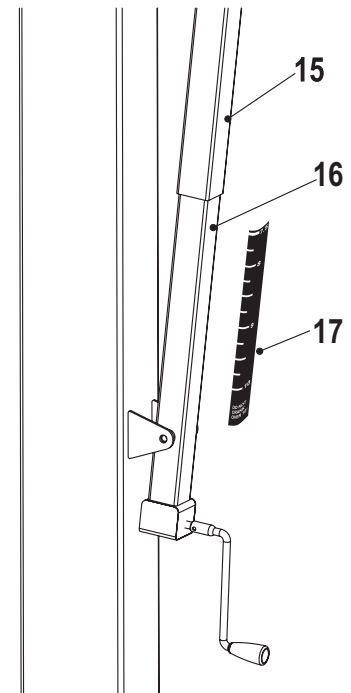
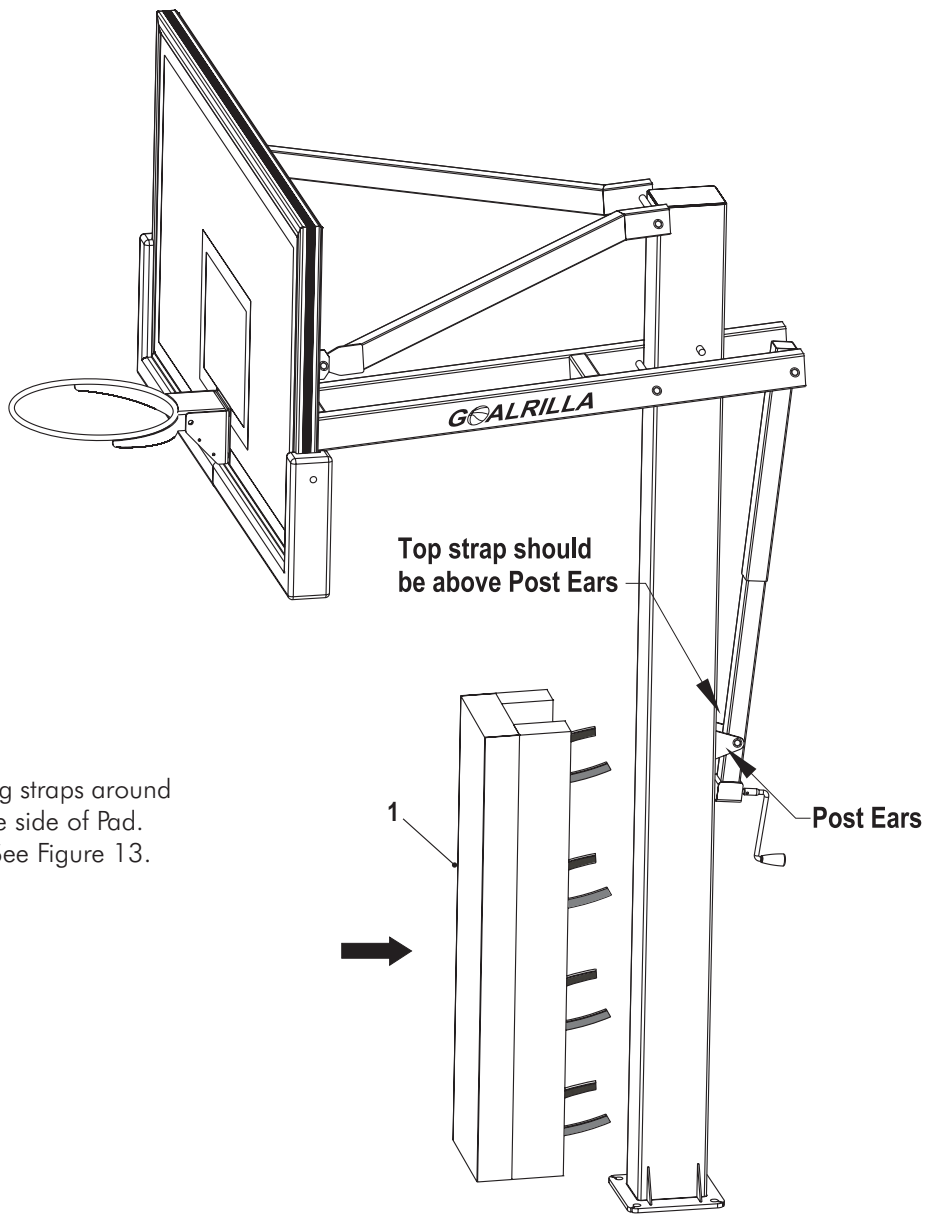

Figure 12



24. Secure Post Pad (#1) to front of pole by wrapping straps around the back pole and sticking to velcro on opposite side of Pad. Top Post Pad straps should be above Post Ears. See Figure 13.

Figure 13

CARE INFORMATION

BACKBOARD CARE AND MAINTENANCE

Items needed to clean backboard:

- 100% cotton soft cloth, (only)
- Glass cleaner

Clean backboard using only a **100% Cotton** soft cloth and glass cleaner. Clean glass as you would clean household windows. Strong cleansers will damage backboard and void warranty.

RIM

Only hang from the rim briefly to regain balance or avoid injuring others. Release the rim as soon as safely possible. Rims are not warranted for any defects other than workmanship. Torn back plates, damaged springs, bent rings, damaged eye bolts, and torn or distorted rim supports result from hanging on the rim and are not warranted.

The goal should not be cranked over 10'. Adjustments of the goal should be done under adult supervision.

When attempting slam dunk activity you should always wear a mouth guard to avoid dental injury.

LIMITED LIFETIME WARRANTY

This consumer warranty extends to the original consumer purchase of any Escalade® Sports Product (hereinafter referred to as the Product).

WARRANTY COVERAGE: Escalade® Sports warrants to the original Consumer Purchaser that any Product of its manufacture is free from defects in material and workmanship. THIS WARRANTY IS VOID IF THE PRODUCT HAS BEEN DAMAGED BY ACCIDENT, UNREASONABLE USE, NEGLIGENCE, IMPROPER SERVICE, FAILURE TO FOLLOW INSTRUCTIONS PROVIDED WITH THE PRODUCT OR OTHER CAUSES NOT ARISING OUT OF DEFECTS IN MATERIAL OR WORKMANSHIP.

Subject to proper installation and normal use, Escalade® Sports warrants, subject to the limitations below, to the original retail purchaser all structural components of the Goalrilla System to be free of defects in material and workmanship for the duration of ownership by the original retail purchaser.

Merchandise must be shipped prepaid with a copy of proof of purchase to Escalade® Sports factory for examination to determine if the basketball system needs to be repaired or replaced. Any labor costs, travel expenses and any other changes involved in the removal, installation or replacement of the defective/repared parts from/to your Goalrilla System will be the purchaser s responsibility. Shipping charges for replaced or warranted merchandise sent back to the customer from Escalade® Sports factory must be prepaid by the customer in advance. If not, the replacement shipment will be sent out collect.

Escalade® Sports reserves the right to examine photographs or physical evidence of merchandise claimed to be defective, and to recover said merchandise, prior to authorization of warranty claims. A Returned Goods Authorization number may be required, please call for details prior to the return of any photographs or merchandise.

This limited lifetime warranty is expressly in lieu of all warranties, expressed or implied, including warranties of merchantability or fitness for use. Escalade® Sports does not assume or authorize any person or representative to assume for us, any other liability in connection with the sale of our products.

The remedy of repair or replacement stated above is Escalade® Sports exclusive remedy. Escalade® Sports will not be liable for any other damages or expenses which may incur, including but not limited to incidental or consequential damages. Escalade® Sports assumes no other obligations or liability on the part of the purchaser, and Escalade® Sports neither assumes nor authorizes any other person to assume for it any other liability in connection with the goods sold.

This warranty shall not apply in any manner to parts or accessories not manufactured by Escalade® Sports.

NOT COVERED BY THIS WARRANTY

- Any merchandise subjected to abuse, negligence, improper installation, vandalism, acts of God, alteration of product, or any other events beyond the control of Escalade® Sports.
- Paint or rusted parts. Paint kits will be available to assist in normal maintenance.
- Rims are not warranted for any defects other than workmanship. Torn back plates, damaged springs, bent rings, damaged eyebolts, and torn or distorted rim supports result from hanging on the rim and are not warranted.
- Shipping charges both ways. Note: Any merchandise shipped to Escalade® Sports collect will be refused.
- Dealer service charges, labor charges and travel expenses associated with replacement of repair of warranty item.

WARRANTY DISCLAIMERS: ANY IMPLIED WARRANTIES ARISING OUT OF THIS SALE, INCLUDING BUT NOT LIMITED TO THE IMPLIED WARRANTIES OF MERCHANTABILITY AND FITNESS FOR A PARTICULAR PURPOSE, ARE LIMITED IN DURATION. ESCALADE® SPORTS SHALL NOT BE LIABLE FOR LOSS OF USE OF THE PRODUCT OR OTHER CONSEQUENTIAL OR INCIDENTAL COSTS. EXPENSES OR DAMAGES INCURRED BY THE CONSUMER OF ANY OTHER USE.

Some states do not allow the exclusion or limitation of implied warranties or consequential or incidental damages, so the above limitations or exclusions may not apply to you.

LEGAL REMEDIES: This warranty gives you specific legal rights, and you may also have other rights which may vary from state to state.

WARRANTY GUIDELINES IS REQUIRED FOR ALL WARRANTY CLAIMS

1. Proof of Purchase (original retail purchaser) is required for all warranty claims.
2. Call or write Escalade® Sports to receive a Return Authorization # and determine specific needs.
Phone: 1-888-USA-GOAL / Warranty Dept.
Or Write Escalade® Sports at: Escalade® Sports - P.O. Box 889, Evansville, IN 47706 - Attn: Warranty Dept.
Or E-mail us at: customerservice@escaladesports.com

Key#	Part #	Description	Qty.
1	3M-6895-00	Pole Pad - E1	1
2	1A-6292-10	Post Assembly	1
3	2B-6093-02	1/2 Flat Washer - Black	14
4	2B-6242-01	1/2-13 Nylon Locknut	6
5	3M-6245-01	1-1/4 Plastic Washer - Black	22
6	1A-7026-01	Upper Board Arm	2
7	1B-6218-02	1/2-13 X 11" Hex Bolt-Grade 5	1
8	1B-6219-02	1/2-13 X 12" Hex Bolt-Grade 5	3
9	3M-6893-00	1-1/2" X 3" Tube Plug	2
10	3M-6464-00	2" X 4" Tube Plug	4
11	1A-6944-01	Lower Board Arm	1
12	1B-6821-00	#10 X 1-1/8 Self Tapping Screw	8
13	3M-6892-00	Actuator Cap	1
14	8S-6566-01	Pivot Tube	1
15	2M-6487-00	Actuator Sleeve	1
16	4A-7699-00	Actuator (Square)	1
17	4L-7434-00	Height Decal	1
18	2B-6094-02	1/2 Split Lock Washer - Black	2
19	1B-6215-02	1/2-13 x 1" Hex Bolt - Black	2
20	1B-6944-00	1/2-13 X 1 3/4" Hex Bolt - Black	2
21	4A-6877-00	Rim Support	1
22	7B-6439-00	Step Bushing - Two way	2
23	6A-7411-00	Backboard Assembly - 42 X 72	1
24	2B-6238-00	3/8-16 Locknut	4
25		Not Used	-
26	2B-6237-00	3/8 Flat Washer	4
27	3M-6466-00	5X5 Rim Pad	1
28	6A-6328-02	Goal Assembly	1
29	1B-6782-00	3/8-16 X 1-3/4 Carriage Bolt	4
30	3F-6010-00	Net	1
31	2S-6421-00	Rim Cover Plate	1
32	1B-6238-01	#8 x 1/2 Thread Forming Scr.	4
33	7B-6391-01	Step Bushing	2
34	3M-6469-00	5/8 Thread Protector	4
35	2B-6097-02	5/8-11 Hex Nut	12
36	2B-6099-02	5/8 Split Lockwasher	4
37	2B-6098-03	5/8 SAE Flat Washer Zinc	8
38	2S-6494-00	Anchor Plate	1
39	2B-6096-00	5/8-11 X 18 "J" Bolt	4
40	1S-6152-00	#3 X 40" Rebar	4
41	7B-6287-00	Pull Pin	1
42	4A-6782-00	Actuator Handle	1
43	2L-7167-00	This Manual	1
44	3M-6894-00	72 Backboard Pad- Right	1
45	3M-6894-01	72 Backboard Pad- Left	1

