

# IRONCLAD SPORTS , INC GAME CHANGER

ADJUSTABLE BASKETBALL SYSTEM  
ASSEMBLY INSTRUCTIONS AND OWNER'S MANUAL

MODEL: GC55-LG  
(1 piece pole)



**⚠ WARNING ⚠**

FAILURE TO COMPLY WITH ANY OF THE WARNINGS IN THESE INSTRUCTIONS MAY RESULT IN SERIOUS PERSONAL INJURY.

FAILURE TO COMPLY MAY ALSO RESULT IN PROPERTY DAMAGE. PLEASE HEED ALL WARNINGS AND CAUTIONS TO ENSURE YOUR SAFETY.

DO NOT ATTEMPT TO ASSEMBLE THIS SYSTEM WITHOUT CAREFULLY READING AND FOLLOWING ALL INSTRUCTIONS. BEGIN BY IDENTIFYING AND TAKING INVENTORY OF ALL PARTS USING THE PARTS LIST PROVIDED.

IRONCLAD SPORTS, INC  
902 Corey Road, Hutchinson, KS 67501  
Telephone: 620-662-2233  
[www.ironcladsports.com](http://www.ironcladsports.com)

Keep this instruction manual in case you have to contact the manufacturer for replacement parts.

## SAFETY INSTRUCTIONS

**FAILURE TO FOLLOW THESE WARNINGS MAY RESULT IN SERIOUS INJURY AND/OR PROPERTY DAMAGE.**

**FAILURE TO DO THESE SAFETY INSTRUCTIONS MAY RESULT IN SERIOUS INJURY, PROPERTY DAMAGE AND WILL VOID WARRANTY.**

Owner must ensure that all players know and follow these rules for safe operation of the system.

To ensure safety, do not attempt to assemble this system without following the instructions carefully. Proper and complete assembly, use and supervision is essential for proper operation and to reduce the risk of accident or injury. A high probability of serious injury exists if this system is not installed, maintained, and operated properly.

- If use a ladder during assembly, use extreme caution.
- 4 people are recommended for this operation.
- Seat the pole sections properly (if applicable). Failure to do so could allow the pole sections to separate during play.
- Before digging, contact utility company to locate underground power cables, gas and water lines. Ensure there are no overhead power lines within 20 ft. (7m) radius of pole location.
- Climate, corrosion or misuse could result in system failure.
- If technical assistance is required, contact us:

## **WARNING**

**FAILURE TO DO THESE WARNINGS MAY RESULT IN SERIOUS INJURY AND/OR PROPERTY DAMAGE.**

Owner must ensure that all players know and follow these rules for safe operation of the system.

- Only hang from the rim briefly to regain balance or avoid injuring others. Release the rim as soon as possible safely.
- During play, especially when performing dunk type activities, keep player's face away from the backboard, and net. Serious injury could occur if teeth/face come in contact with backboard, rim, or net.
- Do not slide, climb, or play on pole.
- When adjusting height, keep hands and fingers away from moving parts.
- Do not allow children to adjust system.
- During play, do not wear jewelry (rings, watches, necklaces, etc.) Objects may entangle in net.
- Keep water and organic material away from pole. Pole can rust and fail.
- Check pole and all metal parts regularly for rust. completely remove rust and repaint with exterior enamel. if rust has penetrated any steel parts, replace that part immediately.
- Check system before each use for loose hardware, signs of rust and instability. Repair before each use. Never play on damaged equipment.
- Wear a mouthguard when playing to avoid dental injuries.

# GC55-LG

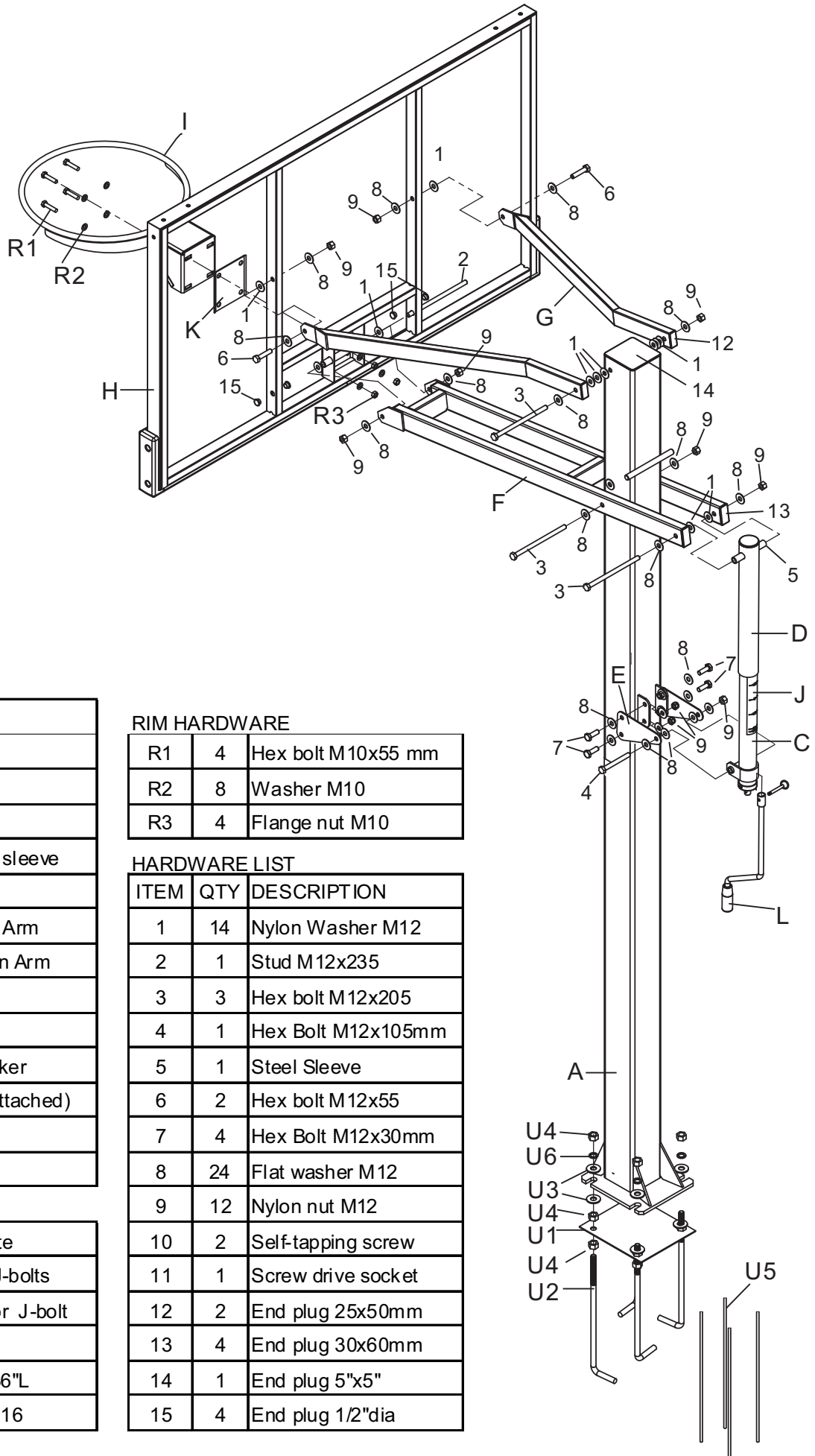

## PARTS LIST

ITEM	QTY	DESCRIPTION
A	1	Post
B		
C	1	Actuator
D	1	Actuator plastic sleeve
E	2	Mounting plate
F	1	Main Extension Arm
G	2	Upper Extension Arm
H	1	Backboard
I	1	Flex rim
J	1	Rim Height Sticker
K	1	Rim Pad (Pre-attached)
L	1	Crank
M	1	Pole padding

## UNDERGROUND PARTS

U1	1	Anchor Template
U2	4	16mm Anchor J-bolts
U3	8	Thick washer for J-bolt
U4	12	Hex nut M16
U5	4	Anchor Rebar 36"L
U6	4	Lock Washer M16

## RIM HARDWARE

R1	4	Hex bolt M10x55 mm
R2	8	Washer M10
R3	4	Flange nut M10

## HARDWARE LIST

ITEM	QTY	DESCRIPTION
1	14	Nylon Washer M12
2	1	Stud M12x235
3	3	Hex bolt M12x205
4	1	Hex Bolt M12x105mm
5	1	Steel Sleeve
6	2	Hex bolt M12x55
7	4	Hex Bolt M12x30mm
8	24	Flat washer M12
9	12	Nylon nut M12
10	2	Self-tapping screw
11	1	Screw drive socket
12	2	End plug 25x50mm
13	4	End plug 30x60mm
14	1	End plug 5"x5"
15	4	End plug 1/2"dia

Note: GC55-MD comes without backboard pad and pole padding.

# INSTALLATION (Day 1 to Day 4)

Prior to anchor system and goal assembly, call utility services for location of underground utility lines before you dig.

This assembly needs 5 days totally.

**Day 1:** Anchor system installation.

**Day 2-4:** Allow concrete to cure.

**Day 5:** Complete basketball system installation.

**THREE PEOPLE ARE NEEDED TO ASSEMBLE THIS UNIT**

## Tools and materials required for assembly

1. Hammer or Mallet
2. Two Adjustable Wrenches
3. 9/16" Wrench
4. 3/4" Wrench
5. 11/16" wrench
6. 1" Wrench
7. Shovel
8. Concrete 9 Bags (80lbs/bag).
9. Electric Drill
10. Carpenter's Level
11. A minimum of two Ladders
12. Water Supply
13. Tape measure

## Day 1

### Anchor system installation

1. Locate your system close to or on the court. Dig a hole as shown in figure 1. Bell out the bottom.

Assemble anchor system as shown in figure 2: Thread nut M16 (U4) all the way to bottom of threads on J-bolt (U2) insert threads of J-bolt (U2) through hole on anchor plate (U1) and secure with nut (U4).

**Note: Each leg of anchor bolts should face the anchor bolt to the right. See Figure 2.**

2. Mix and pour concrete into hole. follow instructions on concrete bag. Stop about 8" below playing surface.
3. Insert 4 Rebars (U5) into concrete 8" apart making a square in center on hole.
4. Continue to pour concrete into hole. Use a concrete form or wooden form for top 4", until concrete flush with playing surface.
5. Push anchor system into concrete and agitate to eliminate voids in concrete, level and square anchor plate (U1) to playing surface. Clean off any concrete on anchor plate and exposed threads.

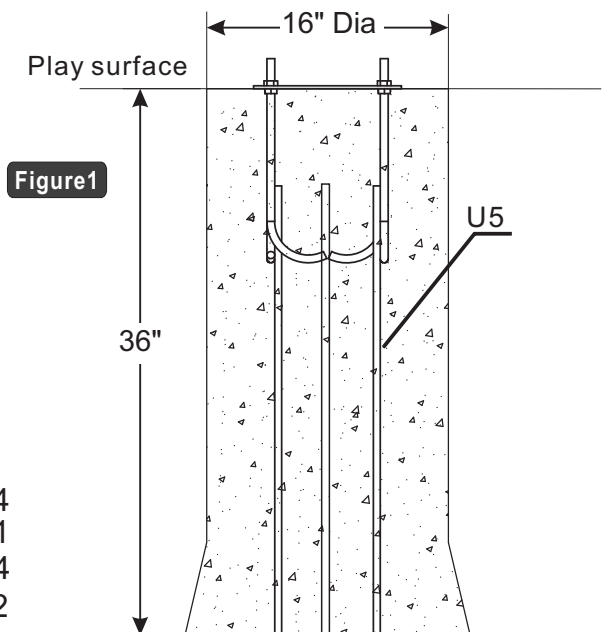
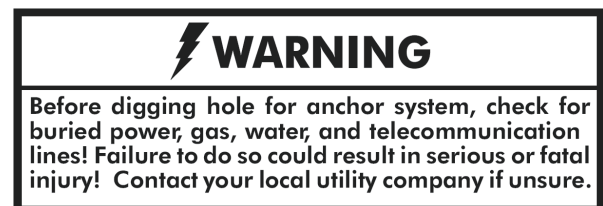
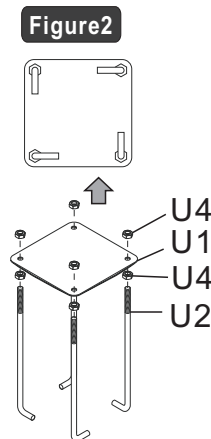

**Warning**  
Never continue to assemble your system without following cementing instructions. Failure to do so may cause serious personal injury or property damage.

You are finished with anchor system.  
Allow concrete cure a minimum of 72hrs.

# INSTALLATION (Day5)

A hammer or mallet may be needed during assembly.

*Note: Do not over tight all arm nuts and bolts. Failure to do so may cause tube damage and make adjustment of system difficult.*

## 1. Place the Pole on the Anchor system.

Slide one Thick washer M16 (U3) over each J-bolt (U2). Lift the Pole (A) onto Anchor system, secure with one thick washer (U3), one Lock washer M16 (U6) and one Hex nut (U4) for each J-bolt. See **Figure 3**.

If the Main Post (A) is not exactly vertical, adjust the 16mm J-Bolt Hex Nuts (U4) located under the Post base (A). Tighten all of the Hex Nuts (U4) Above Post base when Main Post (A) is vertical.

*NOTE: Face the Main Post (A&B) with Actuator Bracket facing away from playing court (as shown in **FIGURE 4**).*

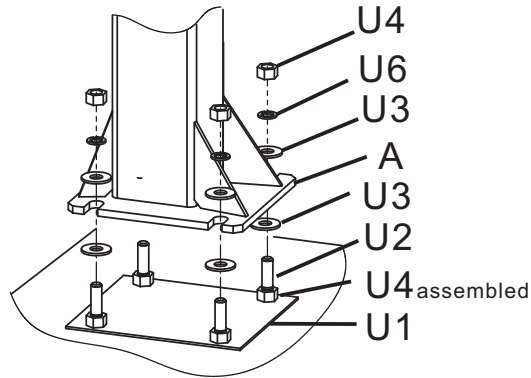

**Figure 3**

Front side

Back side

Playing Court

**Figure 4**

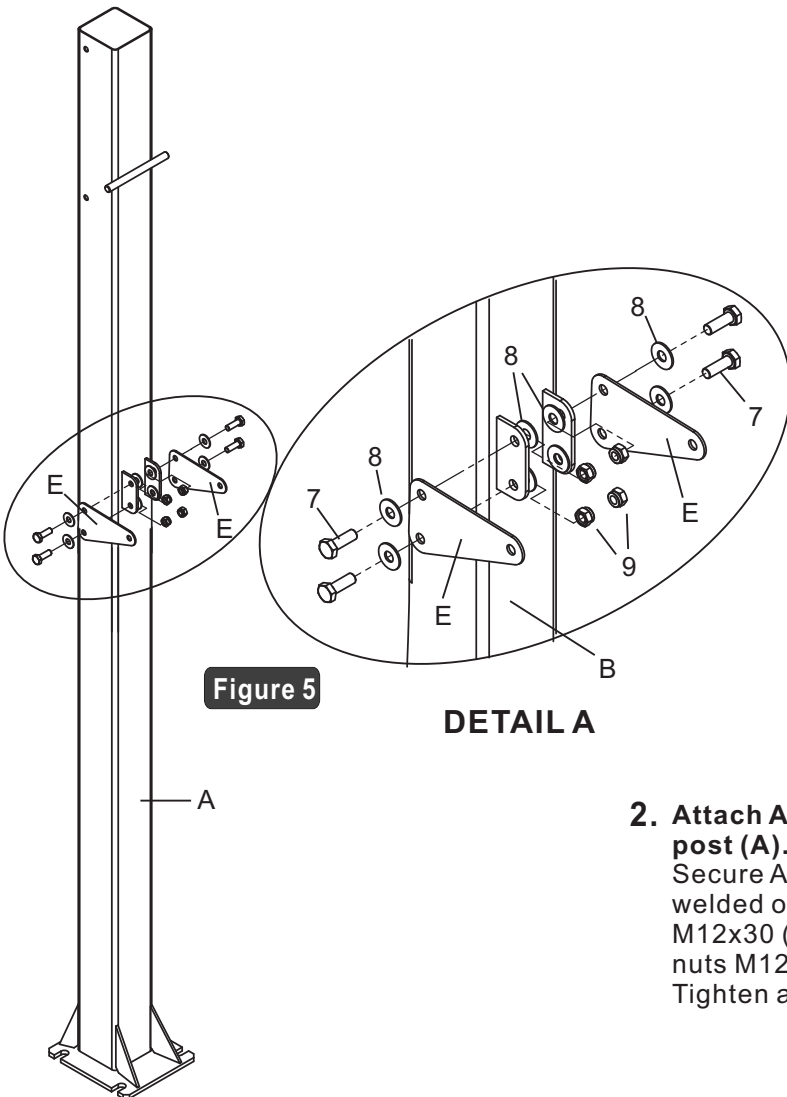

**Figure 5**

**DETAIL A**

## 2. Attach Actuator mounting plate (E) to The post (A).

Secure Actuator mounting plate to the bracket welded on backside of Pole (A) with 4 Hex bolts M12x30 (#7), 8 Flat washers M12 (#8), 4 Lock nuts M12 (#9). See **Figure 5**. Tighten all four nuts and bolts.

**3. Attach Lower Extension arm (F) to Post (A),**  
as shown in **Figure 6**.

Secure it with one Hex bolt M12x205 (#3), two Flat washers M12 (#8), two Nylon Washers M12 (#1)(factory-assembled), and one Lock nut M12 (#9). See **Figure 6**.

**Attach Upper Extension arm (G)to Pole (B),**  
using one Hex bolt M12x205 (#3), two Flat washers M12 (#8), 6 Nylon washers M12 (#1), and one Lock nut M12 (#9). See **Figure 6**.

Note: The plastic washer should be placed between Upper extension arm (G) and Top Pole (B).

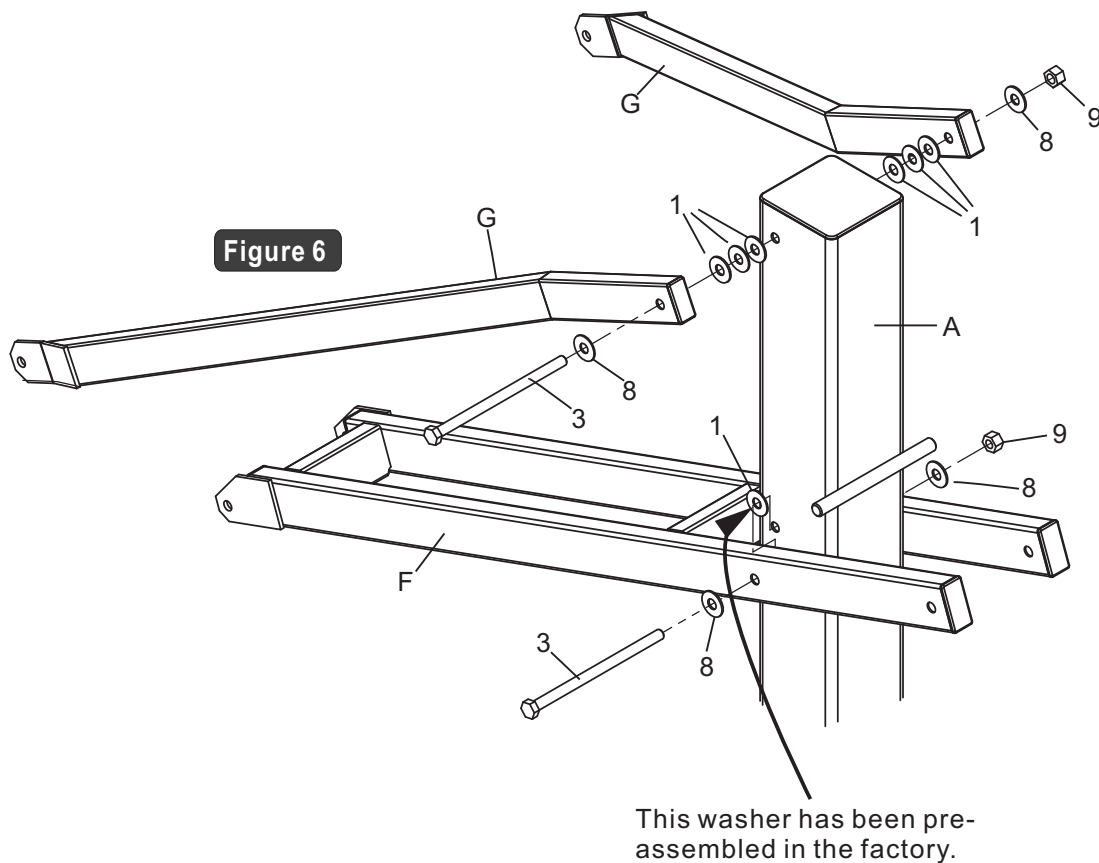

**4. Attach Actuator (C) to Lower extension Arm (F).**

Slide Actuator plastic sleeve (D) over top of Actuator (C), align the hole in the Plastic sleeve with the hole in the Actuator, slide one Steel Sleeve (#5) thru both parts, see **Figure 7**. Hold the Actuator assembly, align Steel Sleeve with the Rear hole of Lower extension Arm (F), Attached them together with one Hex bolt M12x205 (#3), two Flat washers M12 (#8), Two Nylon washers (#1) and one Lock nut M12 (#9). Do not over tighten the bolts.

**Figure 7**

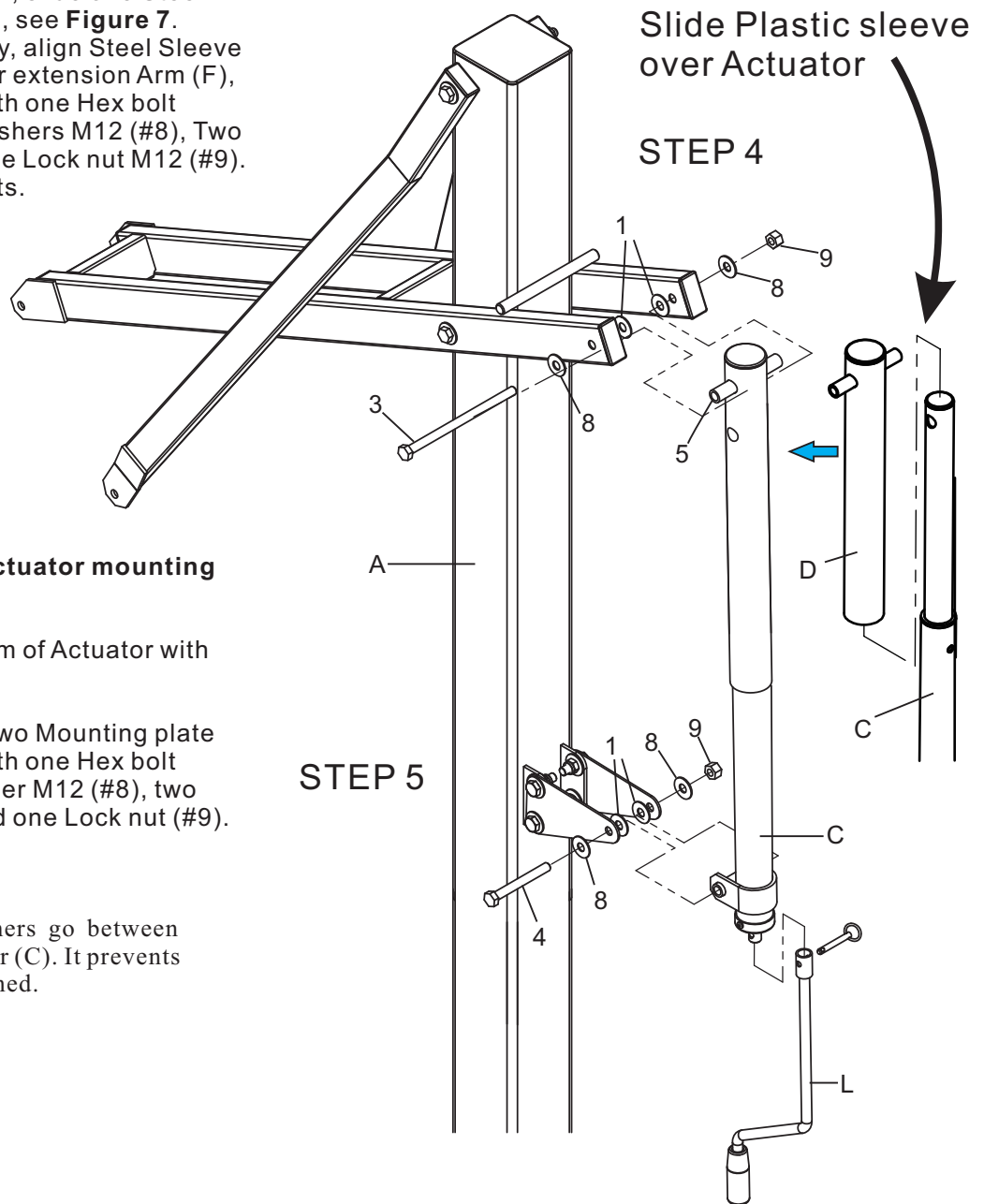

**5. Attached Actuator (C) to Actuator mounting plate (E). See Figure 7**

Attach Crank (L) to the bottom of Actuator with supplied Lock pin.

Crank Actuator in between two Mounting plate (E), secure them together with one Hex bolt M12x105 (#4), two Flat washer M12 (#8), two Nylon washers M12 (#1), and one Lock nut (#9).

Do not over tighten this bolt.

Note: make sure Plastic washers go between Mounting plate (E) and Actuator (C). It prevents painted parts from being scratched.

**STEP 5**

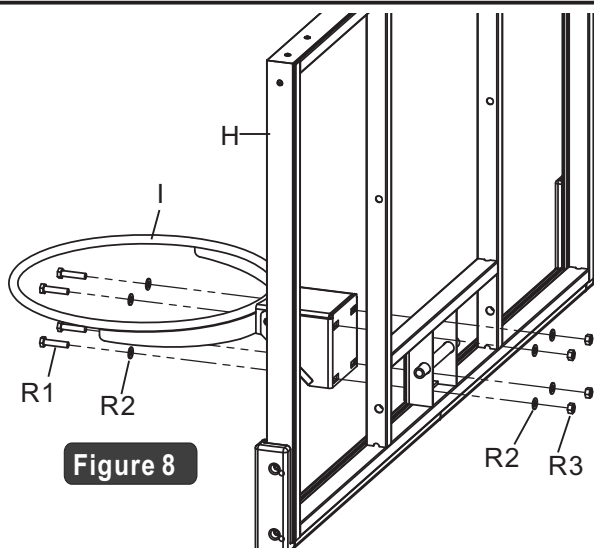

**6. Attach Goal (I) to Backboard (H).**  
Remove the Rim box cover, put Goal against Rim pad (Pre-installed), secure it with 4 Hex bolts M10x45 (R1), 8 Flat washers M10 (R2), 4 Flange nuts M10 (R3) See Figure 12.

Tighten all four bolts and nuts.

Put Rim box cover back and secure it with removed screws.

**Figure 9**

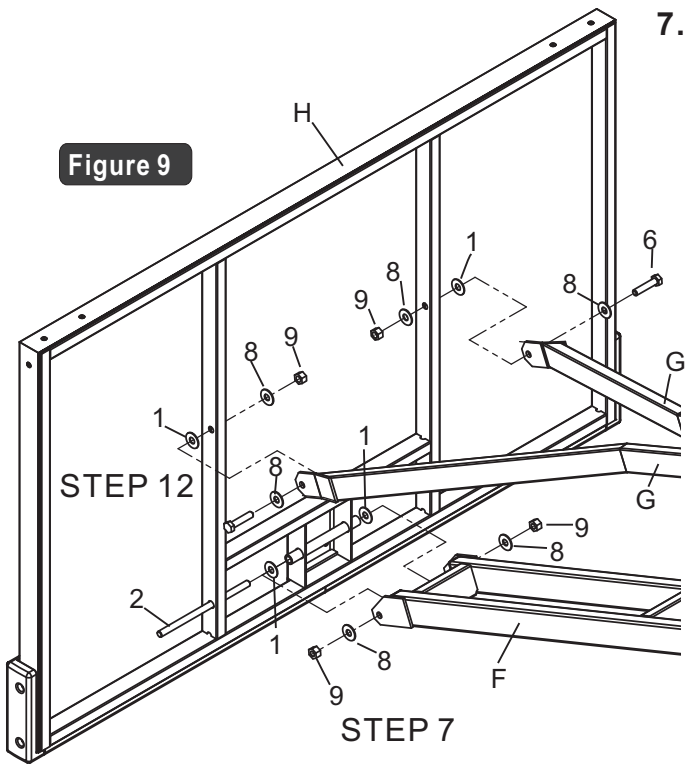

- 7. Attach Backboard (H) to Lower Extension arm (F).**  
Turn crank to lower support frame (F) until against safety stop rod welded on the back of Top Pole (B).

With 3 capable adults, raise the Backboard and rim assembly up and connect Lower Extension arm (F) to the Backboard Bracket using one Stud M12x235 (#2), 2 washers M12 (#8), 2 Plastic washers M12 (#1), and 2 Lock nuts M12 (#9).

Tighten this bolt snugly. See **Figure 9**

Note:

1. Slide the Stud thru from outside of Vertical tubes. After the stud is installed, plug end caps into the holes on the vertical frame, to keep bees from holes. 4pcs plugs can be found in the hardware pack or manual pack.
2. The plastic washer goes between backboard bracket (H) and Lower extension arm (F).

- 8. Attach Backboard (H) to Upper Extension arm (G).**

Connect Upper board arm (G) to the Backboard vertical frame (H) using 2 Hex bolts M12x55 (#6), 4 Flat washers M12 (#8), 2 Plastic washers M12 (#1), and two Lock nuts M12 (#9).

Tighten the two bolts and nuts snugly.

See **Figure 9**.

Note: The plastic washer goes between backboard vertical frame (H) and Upper extension arm (G).

- 9. Apply Rim Height Sticker**

Use a tape measure to crank rim up to exactly 10' from playing surface. Make a line mark on the Actuator (C) against bottom edge of Actuator Sleeve (D).

Crank the rim all the way down to the extreme end. Peel and apply Rim Height sticker (J) to outside of Actuator (C) lining up the mark with the 10' mark on the Rim Height Sticker.

See **Detail B**.

Apply Pole pad if available.

