

## Jam Series Assembly Instructions

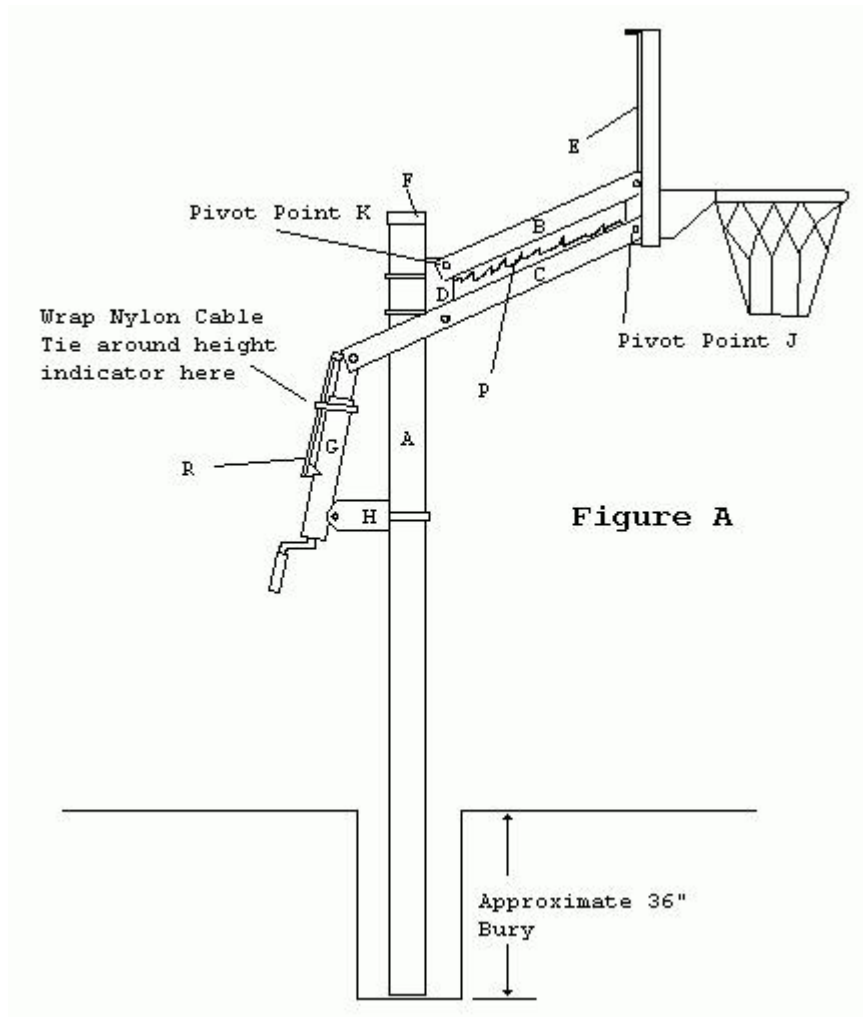

### Bill of Materials

A (1) Vertical Post	K (6) ½" Locknut
B (2) Short Extension Arm	L (3) ½" x 4" U-Bolt
C (2) Long Extension Arm	M (6) ½" Lockwasher
D (1) Extension Arm Support	N (6) ½" Hex Nut
E (1) I-Frame Backboard Mnt.	O (8) ½" Nylon Flatwasher
F (1) 4" Square Post Cap	P (2) Lift Spring
G (1) Crank Assembly	Q (2) Yoke Spacers
H (1) Crank Bracket	R (1) Rim Height Indicator
I (1) ½" x 7½" Hex Bolt	S (1) Rim Height Stickers
J (5) ½" x 11" Hex Bolt	T (1) Nylon Cable Tie
	U (4) 5/16"x1" Machine Bolt

V (4) 5/16" Flatwasher

W (4) 5/16" Lockwasher

X (4) 5/16" Hex Nut

**NOTE: Immediately unpack all components and cross check against bill of materials. Report any shortages to First Team customer service at 1-888-884-6677.**

1. Locate and dig a 12" minimum diameter x 36" deep hole.
2. Fill hole with wet premixed concrete, insert vertical pole leaving 108" above desired playing surface. Vibrate to settle concrete.
3. Make sure post is straight and plumb. Brace while drying if necessary. Allow 24 hours minimum drying time before continuing assembly. Place 4" square post cap on top of pole.
4. Using ½" x 4" U-Bolts, lockwashers and nuts attach the extension arm support to the vertical pole either at desired rim height or at ground level. If you choose to bolt extension arm support up high first, the bottom of the extension arm support should be bolted 93 ½" up from playing surface.
5. Loosely attach all four extension arms to the extension arm support using ½"x 11" hex bolts, ½" nylon flatwashers and hex nuts. (The short extension arms go on top and the nylon flatwashers go between the extension arms and the extension arm support to prevent paint rubbing)
6. Using the 5/16" hardware provided with your backboard, bolt the I-Frame Backboard Mounting (as shown in Figure B) to the center four holes located at the top of your backboard. Remove and discard the plastic shipping block located at the backboard joint
7. **READ THIS ENTIRE STEP BEFORE PROCEEDING:** Attach desired rim loosely with the hardware provided in the rim box. Rim should bolt through backboard and into I-Frame. **ATTENTION:** If your backboard is **ACRYLIC** (FT210, FT215 or FT220) be sure to sandwich one black rubber gasket (provided with backboard) between the backplate of the rim and the face of the backboard and the other gasket between the Backboard I-Frame support and the backside of the backboard when attaching rim. Trim gaskets if necessary. **ATTENTION:** If your backboard is **TEMPERED GLASS** (FT216 or FT221) your backboard should have (4) aluminum core grommets inserted into the glass where the rim bolts through. If they are not in the backboard, look in the box, they may have fallen out during shipping. If you cannot locate all four aluminum cores, **DO NOT PROCEED WITH ASSEMBLY**, call First Team immediately, 1-888-884-6677.
8. Using the 5/16" hardware provided in the bolt bag, attach the I-Frame bottom angle to the bottom four holes in the backboard aluminum frame as shown in Figure B.
9. Attach the Backboard/I-Frame/Rim assembly to the lower set of arms using a ½"x 11" hex bolt and locknut. Use one nylon flatwasher between both extension arms and the I-Frame backboard support to prevent paint rubbing.
10. Attach upper set of arms to the Backboard/I-Frame/Rim assembly using a ½" x 11" hex bolt and locknut. Use one nylon flatwasher between both extension arms and the I-Frame backboard support.
11. Tighten all bolts except where extension arm support mounts to the vertical pole. Make sure rim is square with the backboard, etc.
12. If you are working at ground level, slide the entire assembly up the vertical post until the bottom of the extension arm support is 93 ½" above the playing surface. Make sure entire project is level and square, tighten U-Bolts now. **IMPORTANT!** Do not overtighten U-Bolts, this can cause damage to the extension arm support. Just tighten U-Bolts until they are snug.

13. Using a 1/2" x 4" U-Bolt, lockwashers and nuts, attach the Crank Bracket to the back side of the vertical post so the bottom of the bracket is 61 1/4" above the playing surface, tighten it now. Do not overtighten U-Bolt.

14. Using a 1/2"x 11" hex bolt and locknut, attach the Crank Assembly to the holes furthest back on the lower extension arms as shown in Figure A. Note: While attaching the crank assembly you must simultaneously attach the Rim Height Indicator. The Rim Height Indicator fits between the silver yoked clevis at the upper end of the crank assembly and hangs down along the backside of the crank assembly outer tube, see Figure A. Be sure to also use the (2) Yoke Spacers to keep the silver yoke properly centered between the lower extension arms.

15. With some help, pull down on the Crank Assembly and bolt it to the Crank Bracket using the 1/2" x 7 1/2" hex bolt and lock nut.

16. Attach (2) lift springs from pivot point J to pivot point K as shown in Figure A. You may find it helpful to loop a rope over pivot point K and attach it to one end of the spring. Then with the spring already attached to pivot point J pull down on the rope, extending the spring until it hooks itself over pivot point K.

17. Wrap the Nylon Cable Tie around the Crank Assembly and the Rim Height Indicator and secure until snug. This should keep the metal Height Indicator from "clanging" against the crank body. NOTE: Secure Rim Height Indicator against Crank Assembly high enough that it will not interfere with the Height Indicators range of motion!!! (See Figure A) Trim excess cable tie.

18. Measure rim height to ten feet. Peel and apply the 10' sticker to the Crank Assembly outer tube lining up the 10' sticker with the pointer on the Rim Height Indicator. Follow the same procedure for each of the various heights.

19. Make sure all nuts are tight and project is still level and square.

**Figure B**

